

SMIMO120, Technical Data



smicon
ENGINEERING YOUR PROCESS



Dimensions

Machine general (mm)	3990x2430x1540 (lxwxh)
Infeed (mm)	898x504 (lxw)
Outfeed organic (mm)	2553x844 (lxw)
Outfeed packaging (mm)	844x280 (lxw)
Transport dimensions (mm)	4100x2280x1820 (lxwxh)
Transport volume (m ³)	17
Clear zone (mm)	8000x4500 (lxw)
Filter surface (m ²)	3,55
Filter mesh size (Ø,mm)	8,12,15,20,25,30,50,70

Weight

Weight (kg)	6600
Floor load (kN)	30 per feet (see □) Dynamic
Transport weight (kg)	6800

Drive

Power shaft (kW)	55/75/90
Power filter drum (kW)	0,75
R.p.m. shaft	500
R.p.m. filter drum	2,5
IP rating	56

Product information

Capacity (m ³ /hour)	0 – 35
Temperature product (°C)	0 – 70

Liquid feed

Connection	1" BSP
Temperature (°C)	max. 70
Pressure (bar)	max. 5
Capacity (m ³ /hour)	18
Fouling (mm)	max. Ø2

Other specifications

A-weighted sound pressure level (dB)	80
C-weighted instantaneous sound pressure (dB)	<130

All data are without accessories and specifications depend on used products

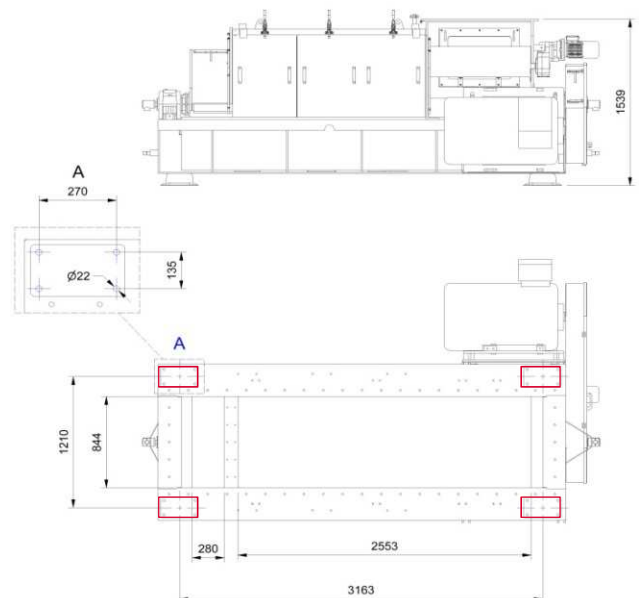
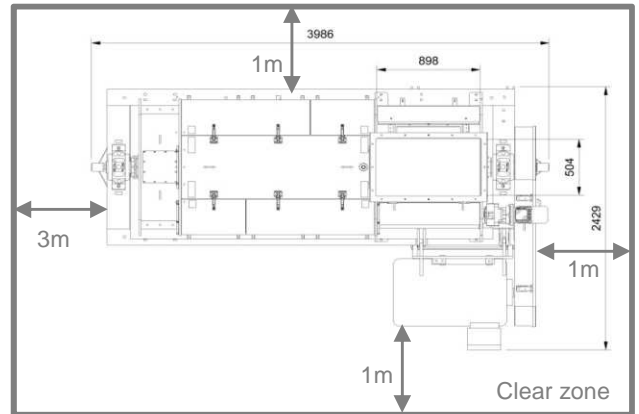

Accessories

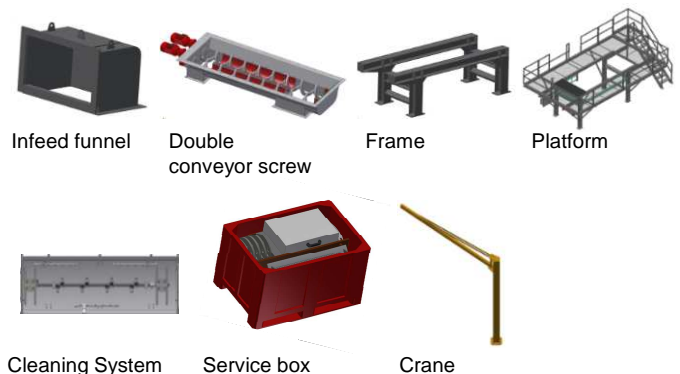

ENGINEERING YOUR PROCESS

www.smicon.nl